

RIDUTTORE AGRP 90Q Gearbox



CODICE D'ORDINAZIONE – Order Code

AGRP	90Q	A2-###	3	Q4-###	...
<i>tipo di riduttore gearbox type</i>					<i>altre opzioni further options</i>
	albero d'entrata input shaft		rapporto ratio	albero d'uscita output shaft	
	S6B: Scanalato 1"6B S6B: Splined 1"6B		3: 1:3	C35: Cilindrico Ø35 C35: Cylindrical Ø35 C40: Cilindrico Ø40 C40: Cylindrical Ø40 MS1: Scanalato 40x36 DIN 5482 MS2: Splined 40x36 DIN 5482 MS2: Scanalato 1"3/8 SAE (P.T.O.) MS2: Splined 1"3/8 SAE (P.T.O.)	

A2 → flangiatura SAE A a 2 fori / SAE A flange with 2 holes

N4 → flangiatura quadrata Ø110 a 4 fori / Square Ø110 with 4 holes

DIMENSIONI ESTERNE – External Dimensions

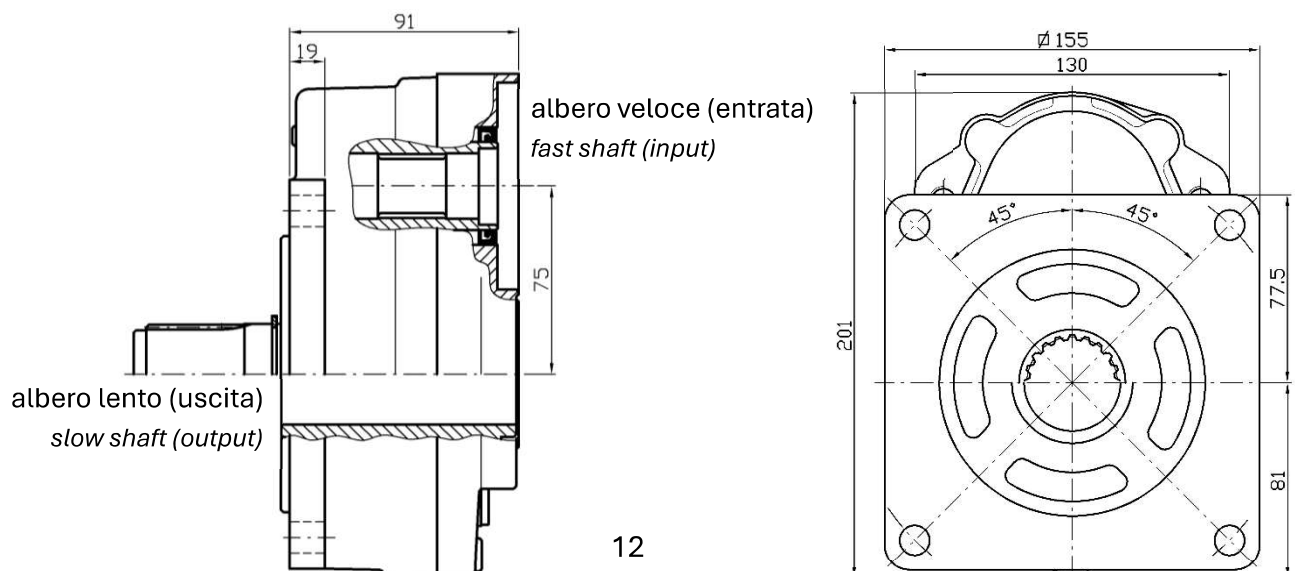

ENTRATE E USCITE – Input & Output

Entrata / Input S6B

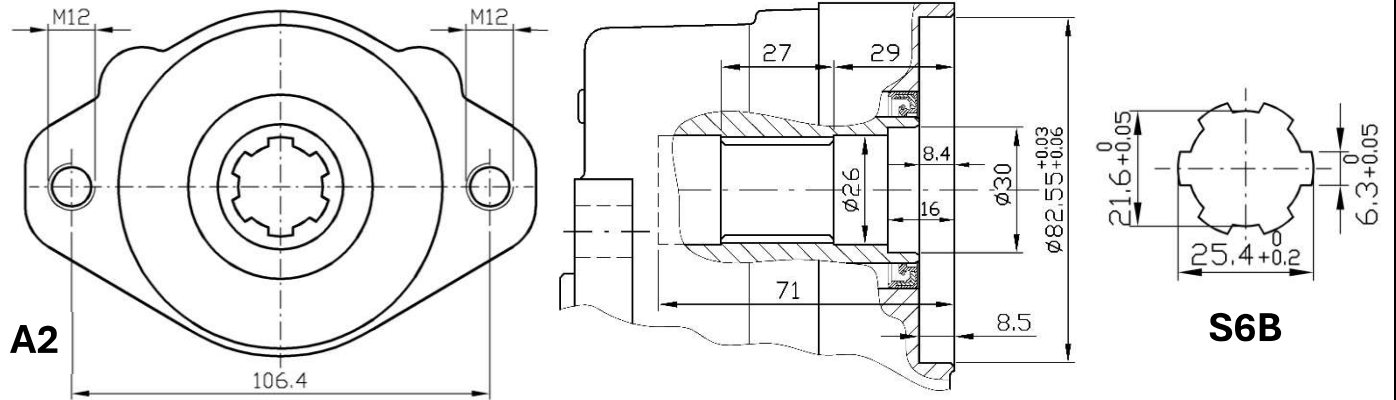

Uscite / Outputs C35 – C40 – MS1 – MS2

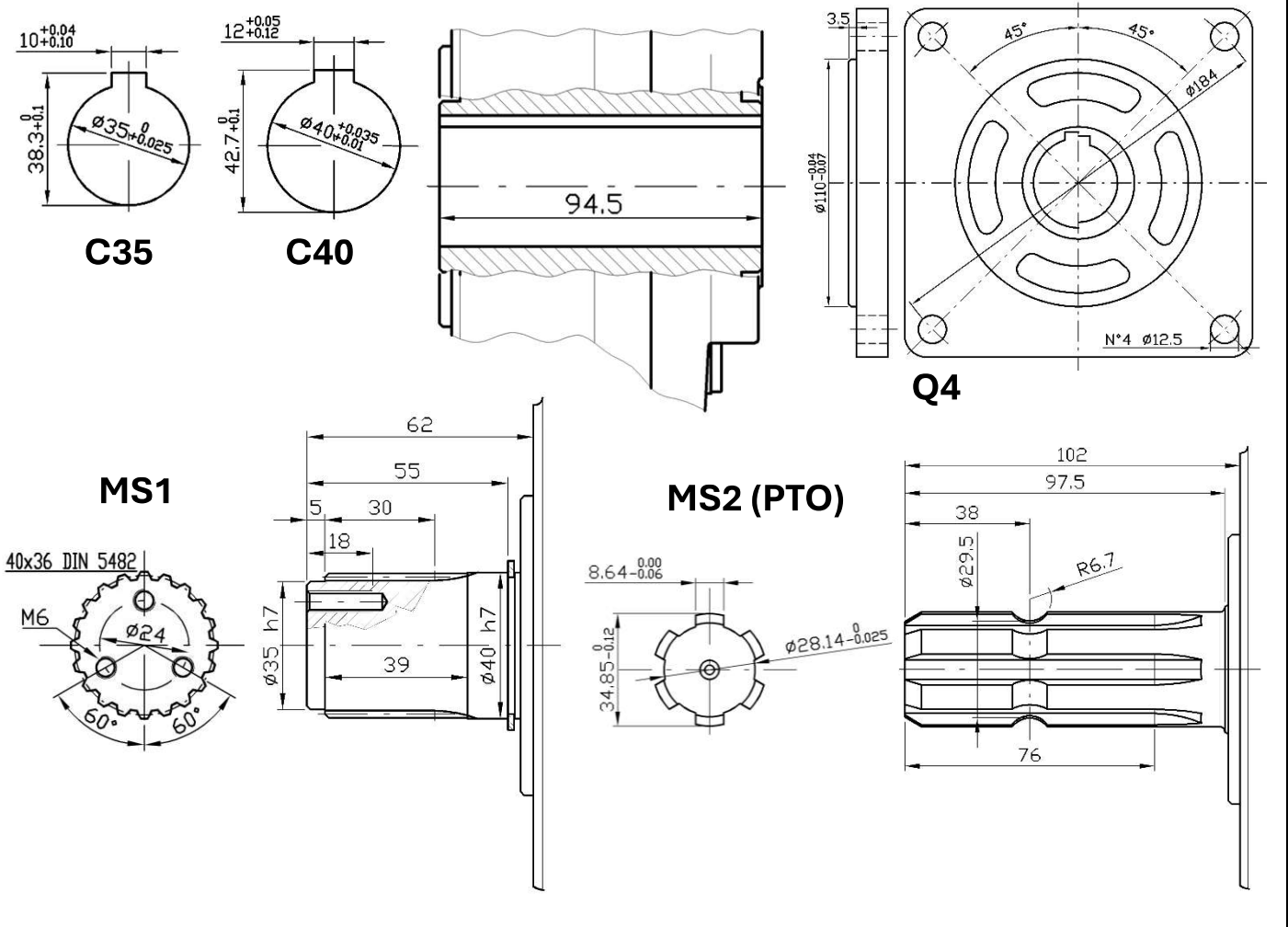

CARICHI – Loads

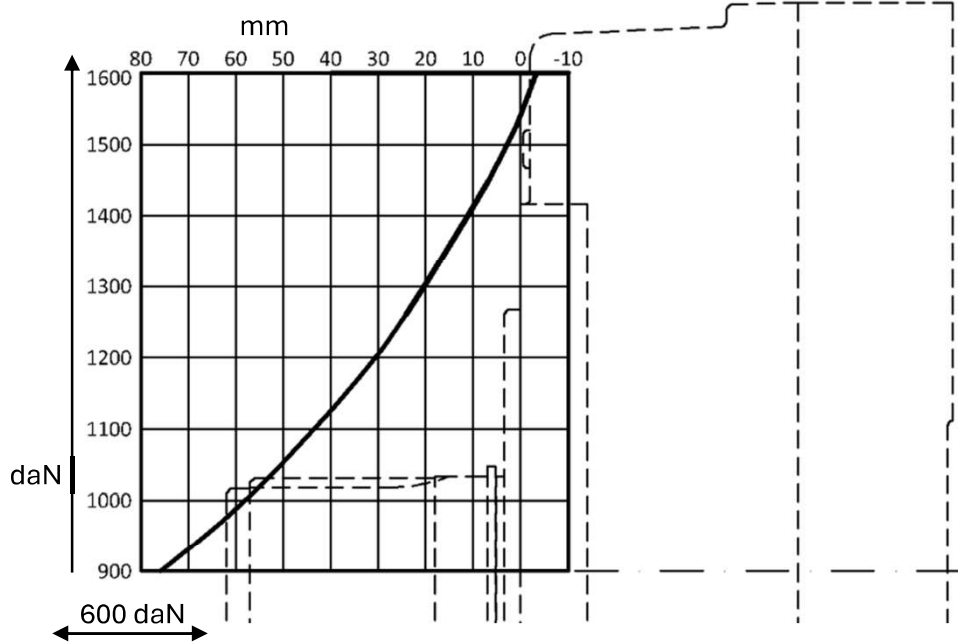

Grafico basato su una durata di 2.000 ore alla velocità di 100 rpm (su albero lento).

Graph based on 2.000 hours life at 100 rpm speed (on slow shaft).